

0 601 8C1 0K0 – GWS 2200

Material number	0 601 8C1 0K0
EAN	3165140972772
Auxiliary handle 1 602 025 030	✓
Backing flange spare part number 2 605 703 014	✓
Cardboard box	✓
Locking nut 1 603 345 043	✓
Protective cover 1 619 P15 622	✓
Two-hole spanner 1 607 950 061	✓



Technical data

Technical data

Rated input power	2.200 W
No-load speed	6,500 rpm
Grinding spindle thread	M14
Main handle	Barrel
Disc diameter	230 mm
Rubber backing pad, diameter	180 mm
Grinding head, diameter	140 mm
Tool dimensions (width)	110 mm
Tool dimensions (length)	475 mm
Tool dimensions (height)	140 mm
Weight	5,4 kg
Switch	Lockable Switch
Noise level	The A-rated noise level of the power tool is typically as follows: Sound pressure level dB(A); Sound power level dB (A). Uncertainty K= dB.

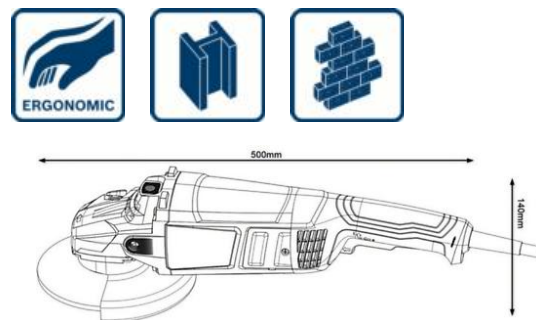

Noise/vibration information

Sound pressure level	104 dB(A)
Sound power level	93 dB(A)
Uncertainty K	3 dB

Segment

Segments	Large Angle Grinders
Mailing segment	Metal Stone

Sales information

Positioning

User benefit

- High material removal rate
- Low breakdown
- Longer carbon brush lifetime
- Low user fatigue